

Magic PV Mount

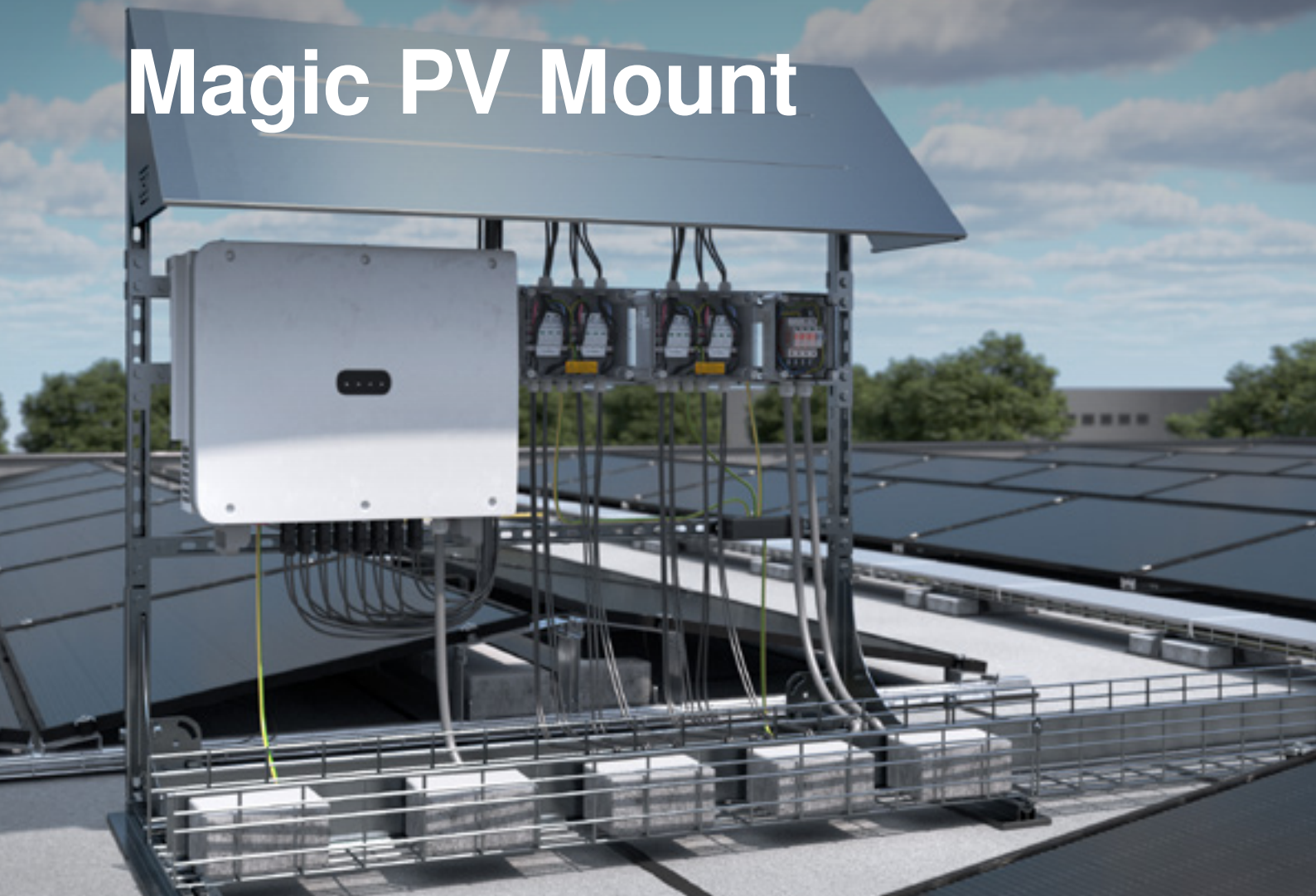

Inverter frame

The Magic PV Mount inverter frame system acts a stand for inverters, for instance, but also for many other components such as the DC connection boxes or combiner boxes. The

robust protective roof minimises the thermal load, which ensures top performance and maximum service life, while also providing protection against precipitation.

Advantages at a glance

- Fast mounting thanks to preassembled modules and sophisticated design
- Compatible with PV mounting systems from the OBO portfolio
- Integrated cable management
- Designed for international wind and snow load zones, including documentation according to Eurocode



www.obo-bettermann.com

St FT/VA

Inverter frame for wall mounting

Type	Length mm	Width mm	Height mm	Min. order- ing quan- tity Piece	Item no.
WRR W1000	468	1082	1501	1	5904005
WRR W1500	468	1582	1501	1	5904007

Inverter frame for the protected installation of several inverters for PV systems on flat roofs. Mounting on the wall.

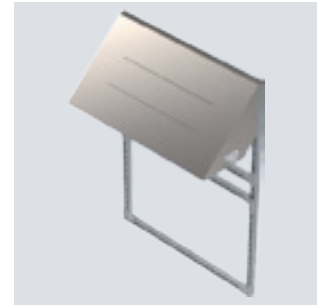
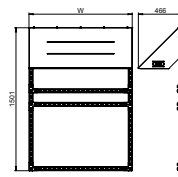

St FT/VA

Inverter frame, free-standing

Type	Length mm	Width mm	Height mm	Min. order- ing quan- tity Piece	Item no.
WRR F1000	725	1151	800	1	5904013
WRR F1500	725	1651	1554	1	5904015

Inverter frame for the protected installation of several inverters for PV systems on flat roofs. Free-standing. Mesh cable tray included for ballasting and for the routing of cables.

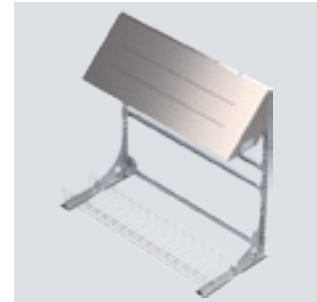
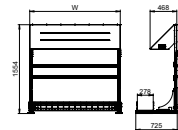

St FT/VA

Inverter frame, free-standing, double-sided.

Type	Length mm	Width mm	Height mm	Min. order- ing quan- tity Piece	Item no.
WRR D1000	1300	1151	1554	1	5904026
WRR D1500	1300	1651	1300	1	5904029

Inverter frame for the protected installation of several inverters for PV systems on flat roofs. Free-standing. Loading on both sides possible. 2 mesh cable trays included for ballasting and for the routing of cables.

