

Mounting instructions

Round cassette for jointless floors

Round cassette for jointless floors

Mounting instructions

Table of contents

1	About these instructions	5
1.1	Target group	5
1.2	Relevance of these instructions	5
1.3	Types of warning information	5
1.4	Basic standards and regulations	5
1.5	Applicable documents	6
2	Intended use	6
3	Safety	6
3.1	General safety information	6
3.2	Personal protective equipment	6
4	Necessary tools	6
5	Product overview	7
5.1	Product description	7
5.2	Accessories	8
5.3	Installation principle	9
5.3.1	Screed types	9
6	Mounting the cassette	9
6.1	Preparations for mounting	10
6.2	Applying the cassette	12
6.3	Preparing for screed laying	14
6.4	Laying the supporting screed	17
6.5	Applying the design screed/Terrazzo covering (facing formwork)	18
6.6	Final work after screed laying	20
6.7	Inserting accessories	21
7	Dismantling the cassette	21
8	Disposing of the cassette	21
9	Technical data	22

1 About these instructions

1.1 Target group

These instructions are intended for the following target groups:

- Trained electrical specialists charged with mounting floor sockets
- Electrical planners and engineers charged with the planning of under-floor systems
- Manufacturers of Terrazzo coverings and ground/polished design screed



Electrical work may only be carried out by specialist personnel with electrical training.

1.2 Relevance of these instructions

These instructions are based on the standards valid at the time of compilation (December 2025).

Please read the instructions carefully before commencing mounting. We will not accept any warranty claims for damage and liability caused through non-observance of these instructions.

Please read the instructions carefully before commencing mounting. We will not accept any warranty claims for damage and liability caused through non-observance of these instructions.

Any images are intended merely as examples. Mounting results may look different.

1.3 Types of warning information



Type of risk!

Shows a risky situation. If the warning information is not observed, then medium or minor injuries may occur.

ATTENTION

Type of risk!

Shows a risky situation. If the warning information is not observed, then damage to the product or the surroundings may occur.

Note!

Indicates important information or assistance.

1.4 Basic standards and regulations

The UZD/UGD55 system components and the height-adjustable cassettes fulfil the requirements of EN 50085-2-2 for electrical installations. The cover of the cassette is used as a protective cover during screed work and thus must only support normal weights of people.

1.5 Applicable documents

The declarations of conformity are linked to the products at www.obo-bettermann.com.

2 Intended use

The design screed solutions are used for the seamless installation of cassettes in combination with underfloor device sockets in ground screed and Terrazzo floors in dry rooms in interior areas, with dry- or wet-care floors.

The cassettes offer installation space for up to twelve sockets in conjunction with electrical installations or numerous data and multimedia connections. Alternatively, 3 cover plates APMT5 can be installed.

The system is not intended for other purposes, particularly not for access to water, wastewater or gas pipelines, or those of other liquids.

3 Safety

3.1 General safety information

Observe the following general safety information:

- Contact with electrical current can lead to an electric shock.
- Risk of cutting from plate edges

3.2 Personal protective equipment

List of personal protective equipment to be used:



Use hand protection

4 Necessary tools

List of tools to be used:

- Tools for fastening (hammer drill, hammer, screwdriver)
- Levelling device (e.g. laser)
- Cutter (knife)
- Screwdriver
- Pozidrive screwdriver PZ2

- Spirit level
- AF5 Allen key

5 Product overview

5.1 Product description

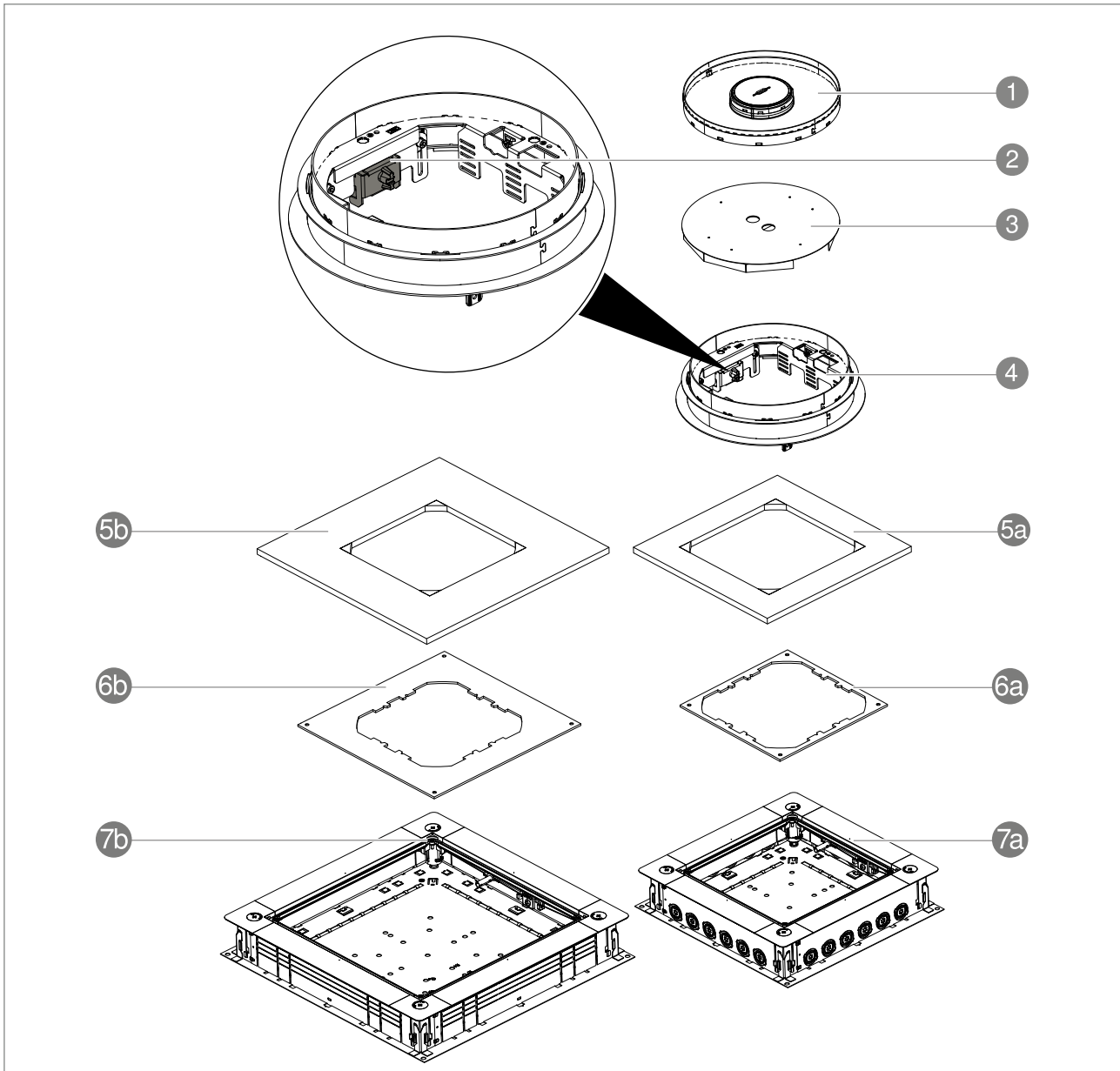

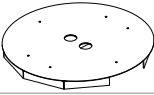

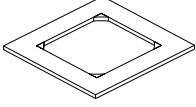
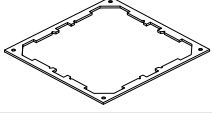
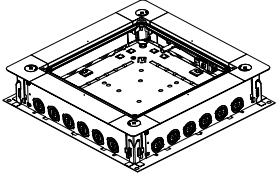

Fig. 1: Product description

No.	Product name	Figure	Function
1	Cassette cover		Cassette cover to close off the cassette after mounting.
2	Holding claws		Holding claws to fix the cassette to the UZD/UGD55 underfloor device socket. The removal of the holding claws decouples the cassette.

No.	Product name	Figure	Function
3	Screed protection cover		The screed protection cover protects the interior of the underfloor device socket against the ingress of screed during mounting.
4	Cassette		Cassette for surface-flush installation with integrated height-adjustment function.
5	ISO apron		ISO apron for insulation/separation of the UZD/UGD55 underfloor device socket and the cassette. Available for nominal sizes 250 and 350 (UZD/UGD55).
6	Mounting lid		The mounting lid creates the fastening points for the holding claws and is screwed to the UZD/UGD55. Available for nominal sizes 250 and 350 (UZD/UGD55).
7	Underfloor device socket UZD/UGD55		UZD/UGD55 underfloor device socket with adjustable installation opening. The height of the underfloor device sockets can be adjusted and thus adapted to different floor heights. The UZD/UGD55 underfloor device socket is not contained in the scope of delivery and must be ordered separately. Available for nominal sizes 250 and 350 (UZD/UGD55).

Tab. 1: Product description



The design screed solution is used for surface-flush, seamless installation of height-adjustable cassettes into the floor area. In doing so, the mounting lid is screwed to the UZD/UGD55 underfloor device socket and the cassette is placed on the mounting lid with the ISO apron.

This means that the non-reduced screed thickness above the underfloor device socket can be used. An aluminium protection cover, which closes the cassette flush, can be polished over with the screed layer.

The cassettes offer installation space for up to 12 Modul 45® built-in devices such as sockets, data and multimedia connections. Alternatively, 3 cover plates APMT5 can be installed.

The side walls of the underfloor device sockets are pre-marked so openings for duct sections and installation pipes can be easily made at the construction site. The socket bodies are made from galvanised sheet steel with a zinc coating of 275 g/m² to EN 10327 DX51D+Z275-N-A-C + AlMgSi profile + PA6 GF30 components + Z410 castings.

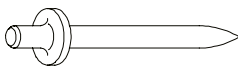
5.2 Accessories

Designation	Figure	Function	Item no.
OBO anchor		The OBO anchor fastens the UZD/UGD55 underfloor device socket to the substrate.	3105016
Flattener		Flattener for OBO anchors.	3031012

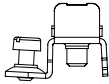
Designation	Figure	Function	Item no.
Protective conductor connection bracket 8AWR		For including underfloor duct systems in the protective measure.	6288704

Tab. 2: Accessories

5.3 Installation principle

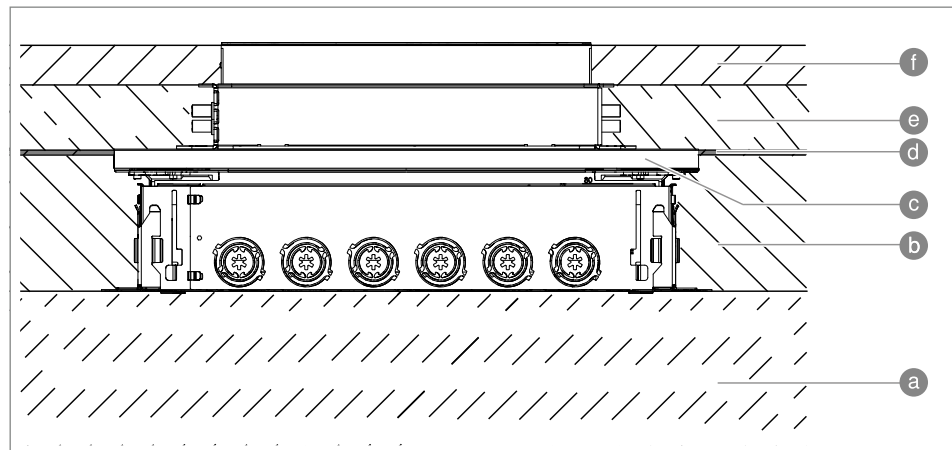

Fig. 2: Installation principle

Components in the floor cross-section (floor structure/height conditions may deviate depending on the floor planning):

- a Raw floor
- b Heat and footfall sound insulation
- c ISO apron
- d PE film
- e Screed (floating support screed)
- f Design screed, Terrazzo covering

5.3.1 Screed types

The screed-covered duct system is suitable for installation in all screed types (according to DIN 18560). Some screed types (magnesia screed, poured asphalt) require appropriate preliminary work due to the properties of the screed materials.

6 Mounting the cassette

6.1 Preparations for mounting



Risk of electric shock!

The duct system must be connected in a manner that is fully conductive! The mounting of the screed-covered duct system takes place on the raw floor, as the required electrical connection would not otherwise be guaranteed.

ATTENTION

Risk of damage!

Product damage to the height-adjustment units! During the construction phase, do not stand on the underfloor device sockets, as otherwise the duct system will not function. Damaged underfloor device sockets must be replaced.

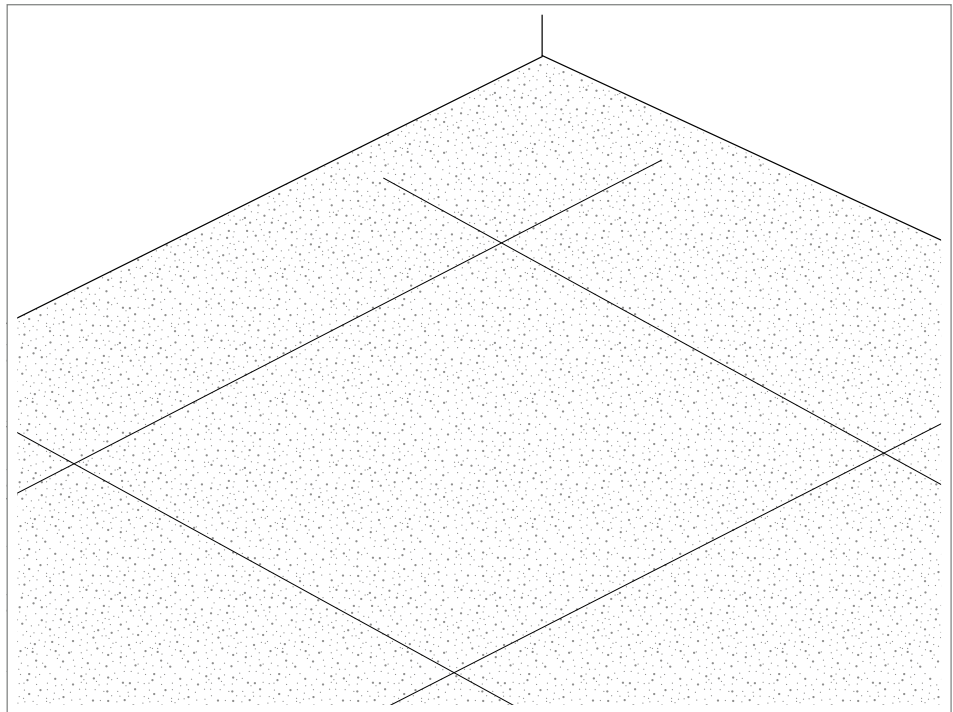

Fig. 3: Preparations for mounting

1. Create a clean, even raw floor as the basis.
2. Mark the planned cable routes and intersection points of the UZD/UGD55 underfloor device sockets ⑦ using a suitable tool (e.g. laser measurement device or chalk line) on the floor.

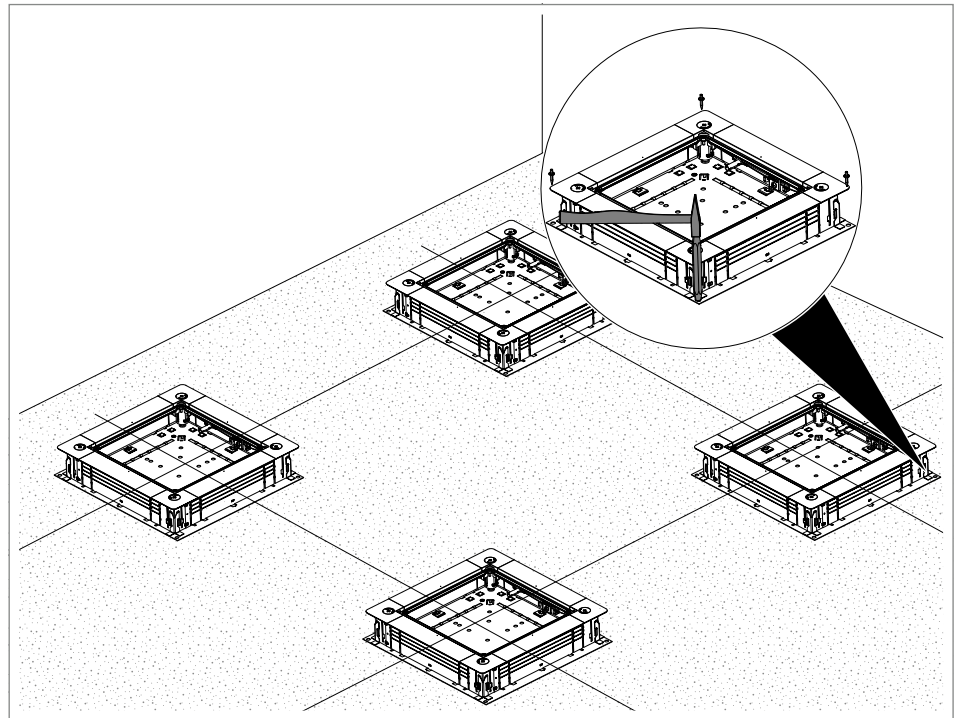

Fig. 4: Fastening the UZD/UGD55 floor device socket

3. Align the UZD/UGD55 underfloor device sockets ⑦ to the intersection points.
4. Fasten the UZD/UGD55 underfloor device sockets ⑦ to the raw floor with suitable fastening material.

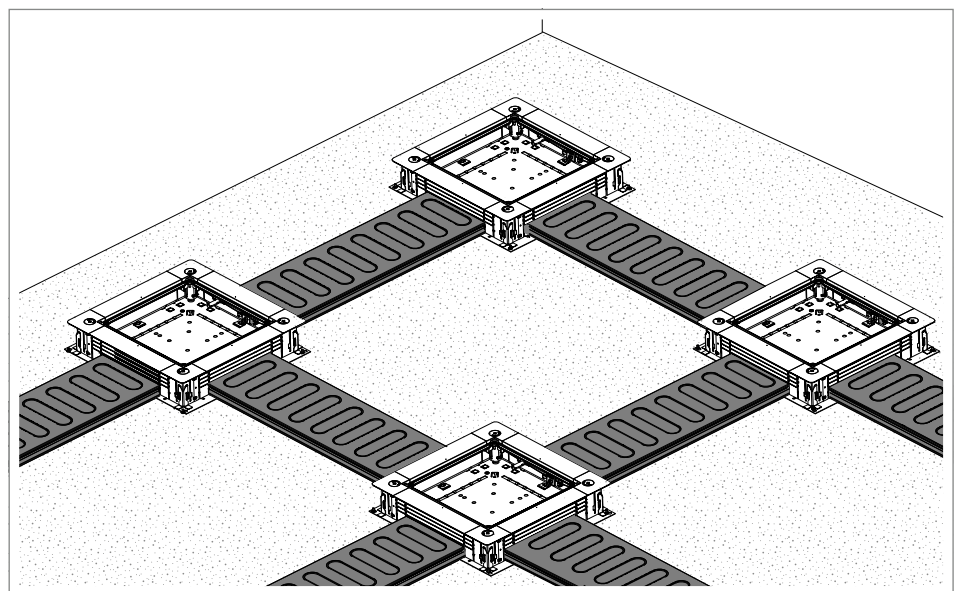

Fig. 5: Connecting the UZD/UGD55 underfloor device socket

5. Connect the UZD/UGD55 underfloor device sockets ⑦ with a suitable duct or trunking system or installation pipes.
6. Install cables.

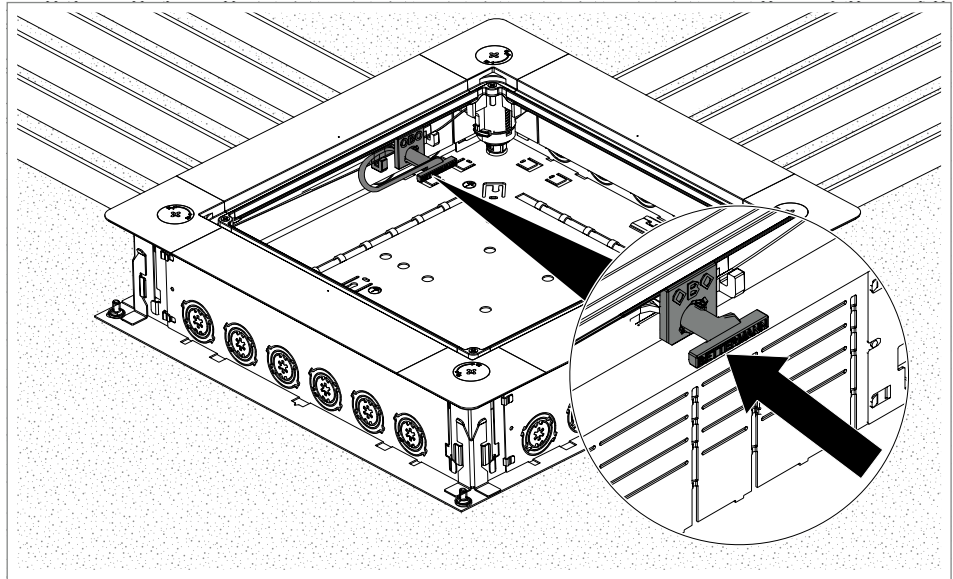

Fig. 6: Adjusting the height of the UZD/UGD55 underfloor device socket

7. Push in the quick height-adjustment aid on both sides.
8. Set the correct levelling height to -12.5 mm (height of the ISO skirt) to the upper edge of the impact sound/thermal insulation.
9. Release the quick levelling aid. This completes the levelling process.

6.2 Applying the cassette

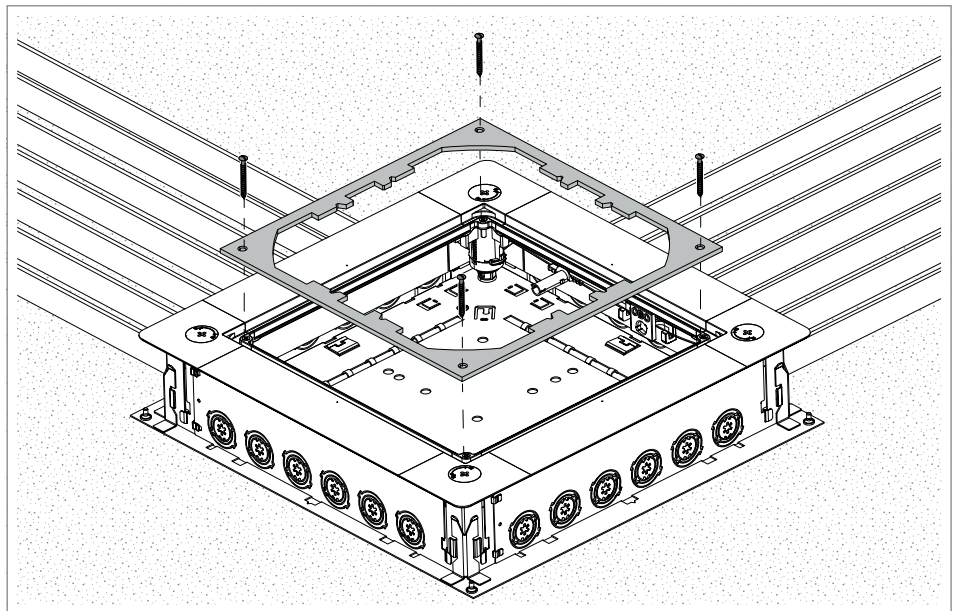

Fig. 7: Applying the mounting lid

1. Place the mounting lid ⑥ into the installation opening of the UZD/UGD55 underfloor device sockets ⑦ and screw it tight.

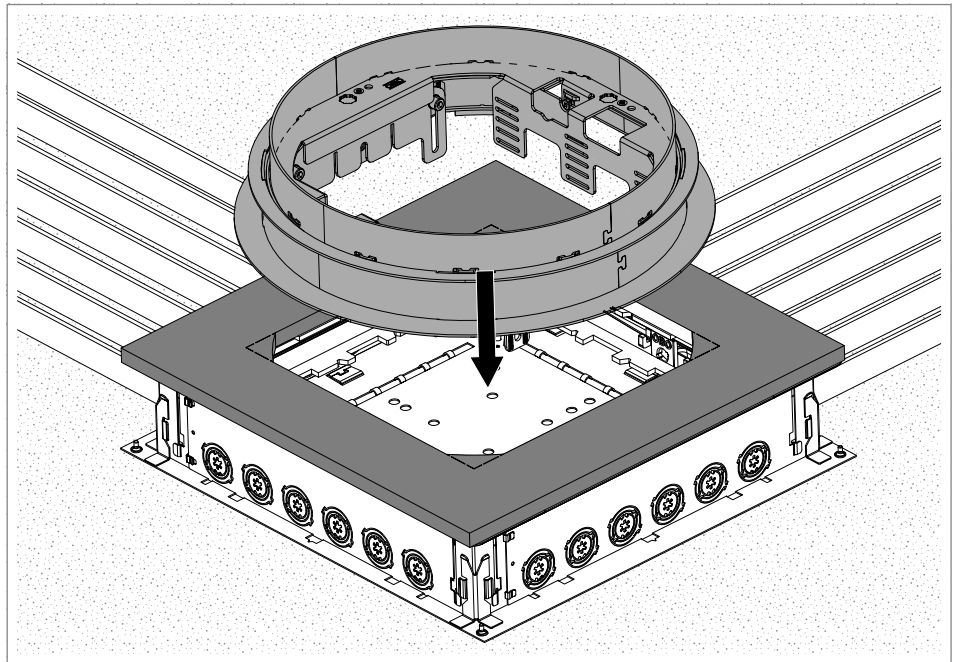

Fig. 8: Applying the ISO apron and cassette

Note! *Do not cut or shorten the ISO apron. The ISO apron must cover the UZD/UGD55 underfloor device socket completely.*

Note! *It is essential to ensure that the upper edge of the impact sound insulation/thermal insulation and the upper edge of the ISO skirt are level!*

2. Place the ISO apron ⑤ and cassette ④ without the holding claws ② on the UZD/UGD55 underfloor device sockets ⑦.

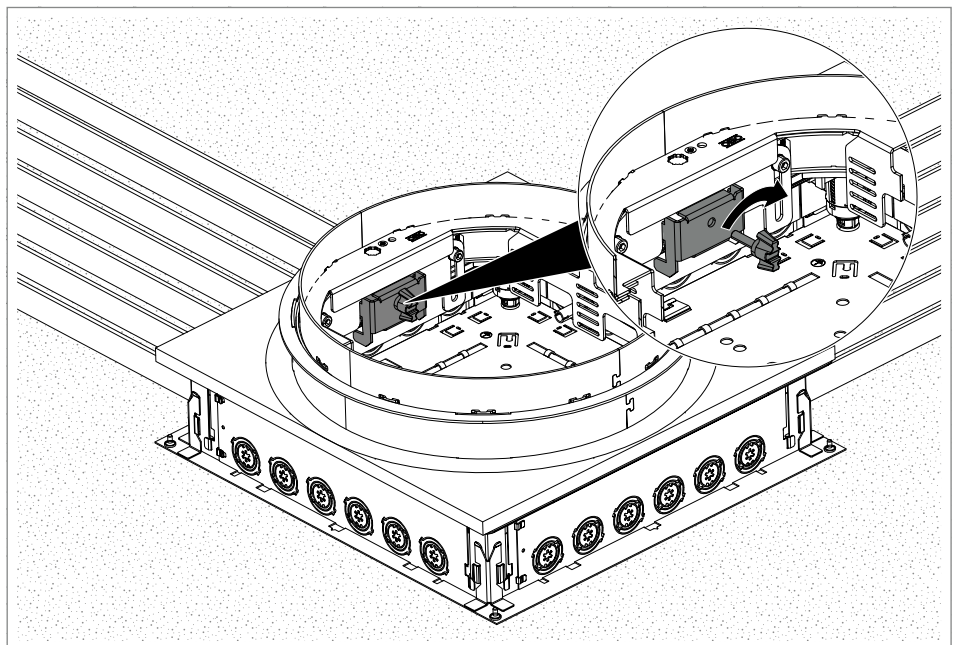

Fig. 9: Fastening the holding claws

3. Fasten the cassette ④ with 2 holding claws ② in the centre of the mounting lid ⑥ by hand.

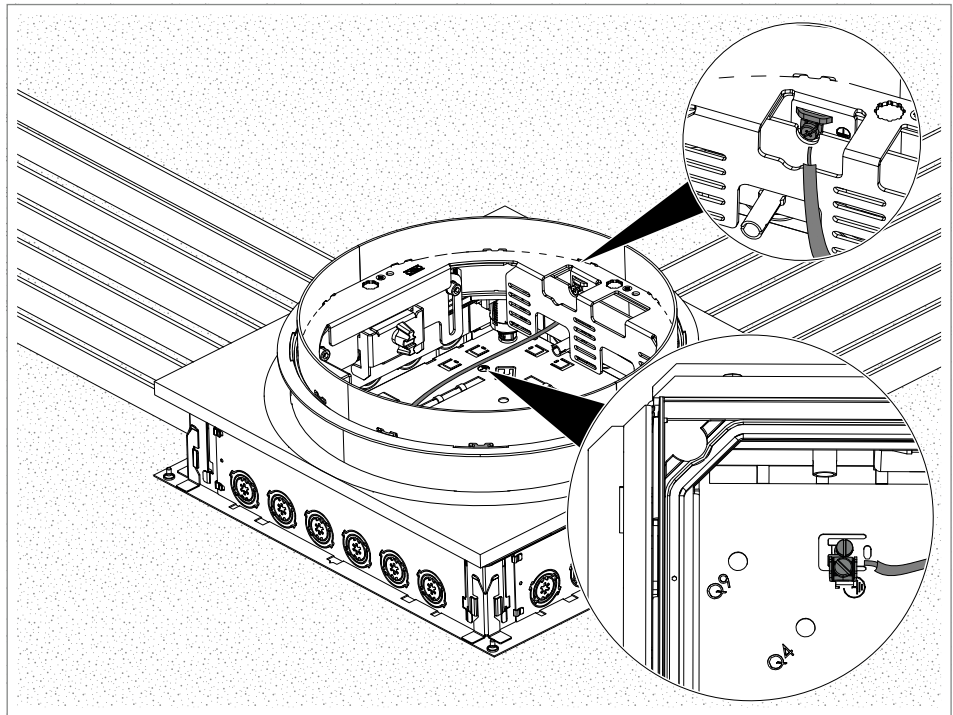

Fig. 10: Establishing equipotential bonding

4. Bend the earthing strap in the base of the UZD/UGD55 underfloor device sockets ⑦ and fasten the 8AWR protective conductor connection bracket.
5. Connect the earthing screw of the cassette ④ and UZD/UGD55 underfloor device sockets ⑦ for the equipotential bonding.

6.3 Preparing for screed laying

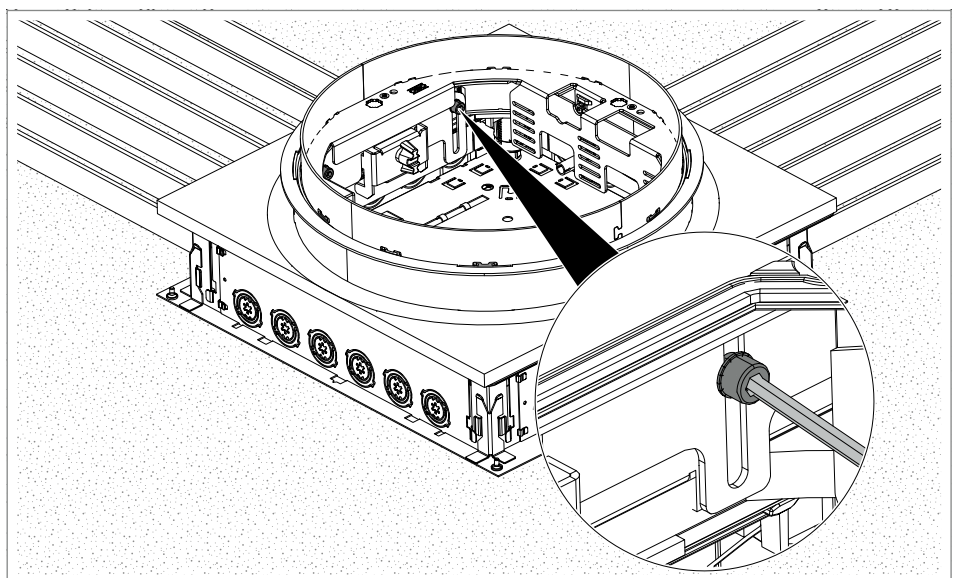

Fig. 11: Fine adjustment of the cassette

Note!

The height-adjustment range (combination of the screed and design screed thickness) is between 73 and 113 mm.

1. Adjust the height of the cassette ④ to the top edge of the design screed using the 4 slots.
2. Tighten the screws (torque: 6-8 Nm).

ATTENTION

Risk of damage!

Make sure to comply with the torque specification of 6-8 Nm. Improper execution can result in damage to the cassette as well as to the floor structure due to the load in operation.

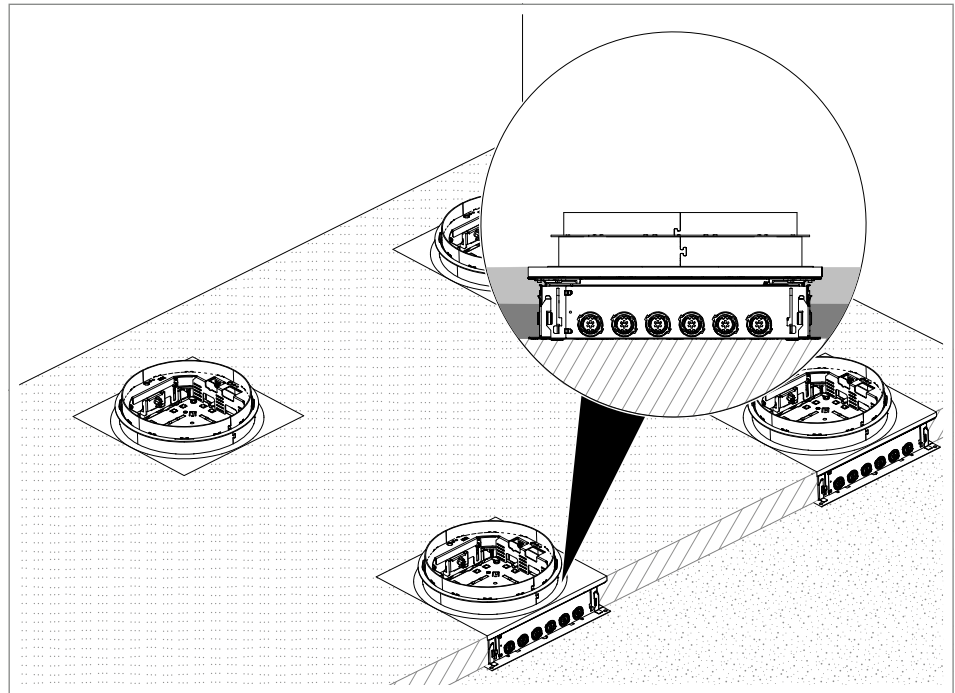

Fig. 12: Inserting the insulation/footfall sound insulation

3. Insert the heat and footfall sound insulation up to the height of the top edge of the ISO apron ⑤.
4. Cover the insulation layer, including the ISO apron ⑤, with PE film.

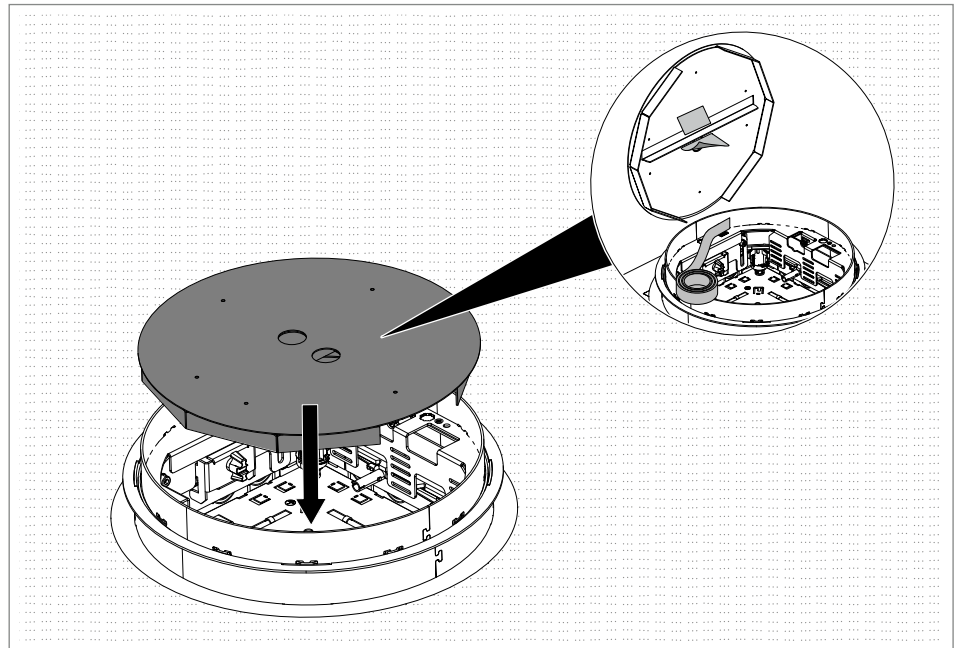

Fig. 13: Mask the cassette and screed protection cover

5. Insert the screed protection cover ³. Insert screed protection cover 3 into the lower part of the cassette ⁴. Remove the standard cassette top part and place it to one side.
6. Mask all the openings on the cassette ⁴ and the screed protection cover ³ from within, in order to prevent the ingress of the screed compound.

ATTENTION

Risk of damage!

Product damage to the cassette/lined body! The lined body and the cassette must be free from grease before treatment with reaction resin. Damage caused by cleaning agents to other units must be avoided.

7. Treat the cassette ⁴ with reaction resin from outside, quartz it and then allow to harden for 24 hours (agreement with the screed layer is required).

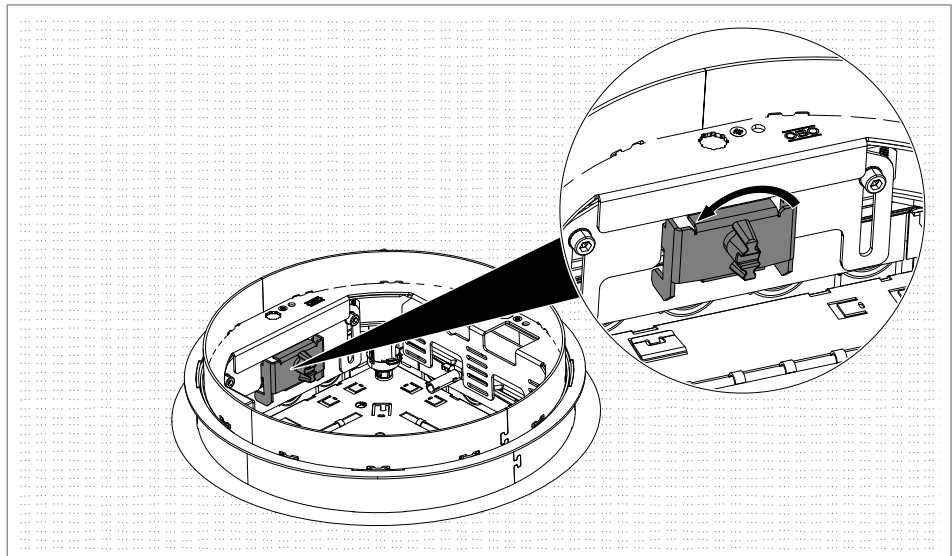

Fig. 14: Decoupling the cassette partly

8. Remove the screed protection cover ③.
9. Loosen the wing screws again so that the retaining claws and wing screws form a loose bearing. Both components must be easily movable.
10. Insert the screed protection cover ③ again.
11. Check the installation height.

6.4 Laying the supporting screed

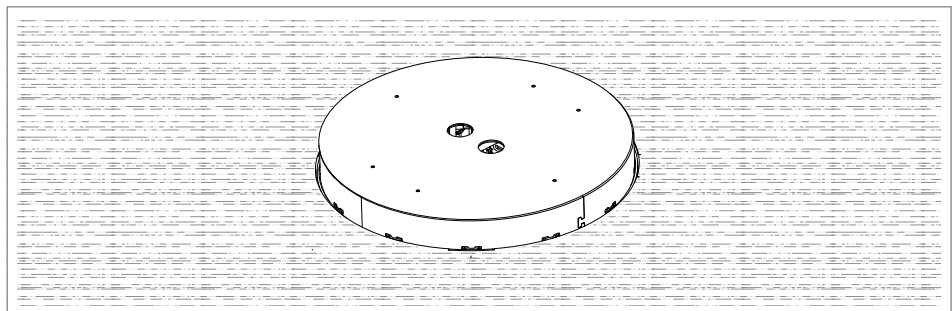

Fig. 15: Laying the screed

1. Apply the floating support screed.
2. Work the floating support screed up to the cassette ④.
3. Let the design screed harden.
4. Once the screed is walkable, remove the retaining claw with the wing screw and dispose of it.

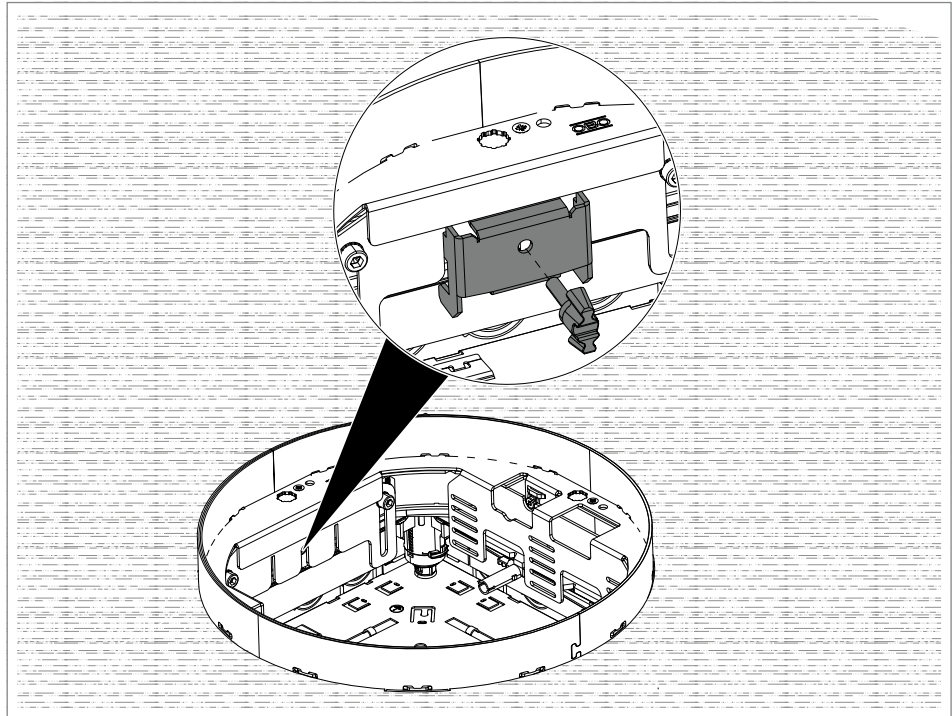

Fig. 16: Decoupling the cassette

5. Replace the screed protection cover ③.

6.5 Applying the design screed/Terrazzo covering (facing formwork)

ATTENTION

Risk of damage!

Product damage to the cassette! During laying, the screed must be properly compacted, particularly around the cassette, so that there is a good connection between the screed and the cassette and crack formation is avoided.

ATTENTION

Risk of damage!

Product damage to the cassette! Maintain a distance to the cassettes when polishing the screed with large machines, as the cassette frame could otherwise be destroyed by the grinding blades. In this area, polishing should take place separately with smaller hand-held machines.

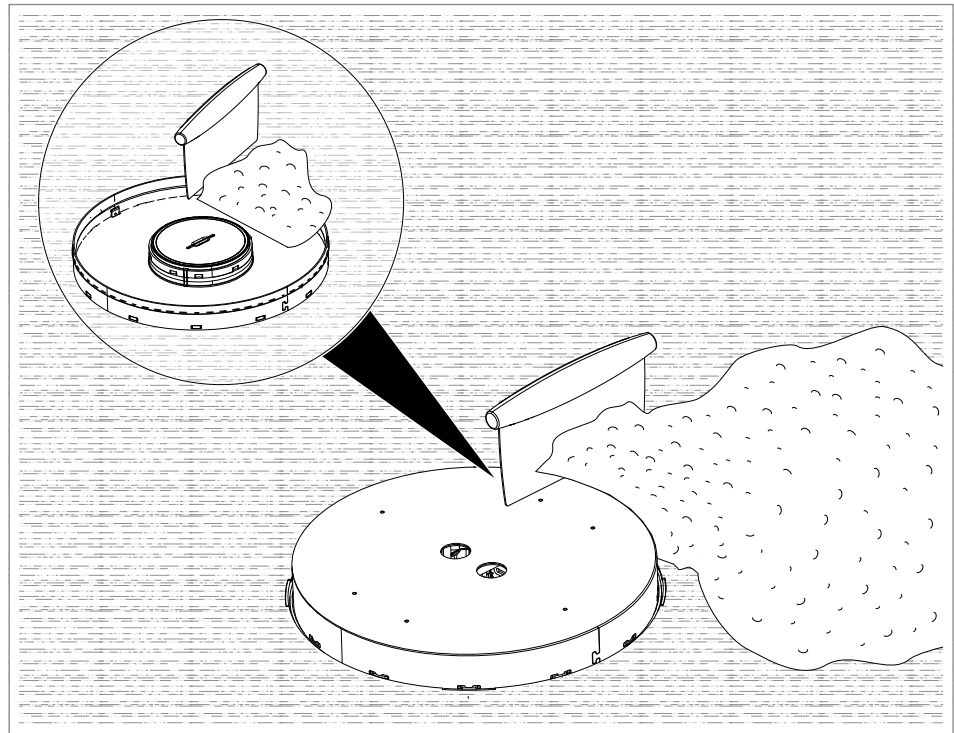

Fig. 17: Applying the Terrazzo covering

1. Apply the design screed/Terrazzo covering (facing formwork) to the floating support screed.
2. Pre-finish the design screed/Terrazzo covering (facing formwork) for the cassette cover ①, polish it and stick it to the cover or apply Terrazzo mortar to the cassette cover ① using a suitable reactive resin bonding course and polish after hardening.

Note! *Do not polish over the aluminium cover of the screed protection cover.*

3. Polish the design screed/Terrazzo covering (facing formwork).
4. Using a hand polisher, work the design screed/Terrazzo covering (facing formwork) up to the cassette ④.

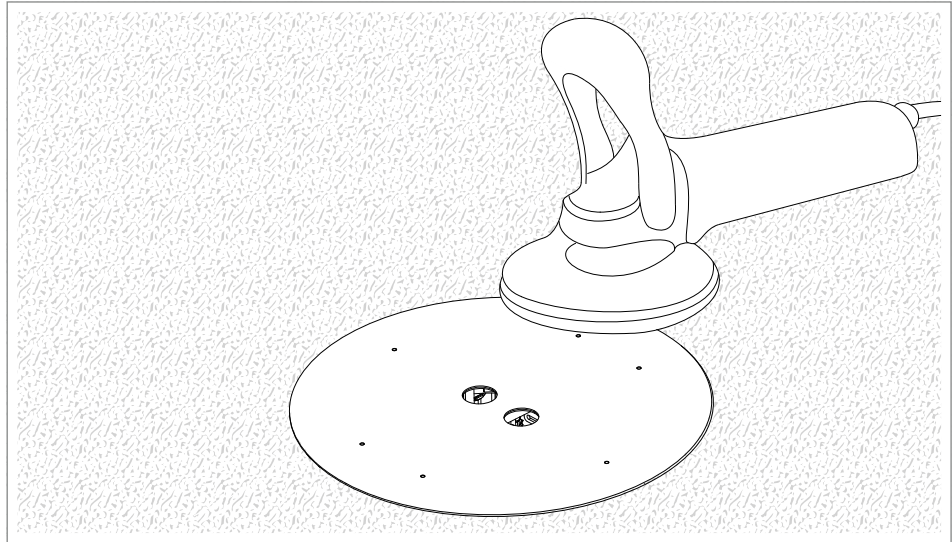

Fig. 18: Working up the Terrazzo covering

5. Remove the screed protection cover ③ and then dispose of it.

6.6 Final work after screed laying

The polishing and smoothing of design screeds and Terrazzo coverings is carried out in multiple work steps. Depending on the type of design, the surface is only polished without any significant removal. The surface is ground coarsely or finely, until the desired particle size and shape on the surface becomes visible. In this case, the design screed/Terrazzo covering (facing formwork) is first installed approx. 3–5 mm higher than the intended target height.

The surfaces are polished using diamond grinding machines.

Hand-held polishing machines are used for the edges of the underfloor sockets with cassette solutions. In doing so, the screed protection cover is also polished in the edge area.

During the entire polishing work, including filling, fine polishing and sealing, the screed protection covering remains in the cassette frame, protecting the components against damage and soiling.

The polishing and additional work must usually be carried out very carefully.

The cassette covers must always be worked separately to the surface working. Due to the delicate structure of the cassette covers, it is important to dismantle the cord outlet covers before work, or to cover the opening for the cord outlet/tube body. The cassette covers can be covered with a Terrazzo plate created and worked from screed mortar in advance. Any gaps appearing between the cassette frame and the plate can be filled and worked with filler. With careful work, the gap area can barely be noticed when finished. Alternatively, the cassette cover can also be filled with mortar and polished after hardening. We recommend specifying the procedure using a sample, in agreement with those involved.

ATTENTION**Risk of damage!**

Product damage to the cassette! Ensure that the top edge of the stainless steel cassette is not sanded down.

6.7 Inserting accessories

Fig. 19: Inserting accessories

Note! If the cassette has not been decoupled (by removing the holding claws), then the outer universal supports cannot be installed.

1. Insert the accessories and universal supports.
2. Insert the cassette cover ①.

7 Dismantling the cassette

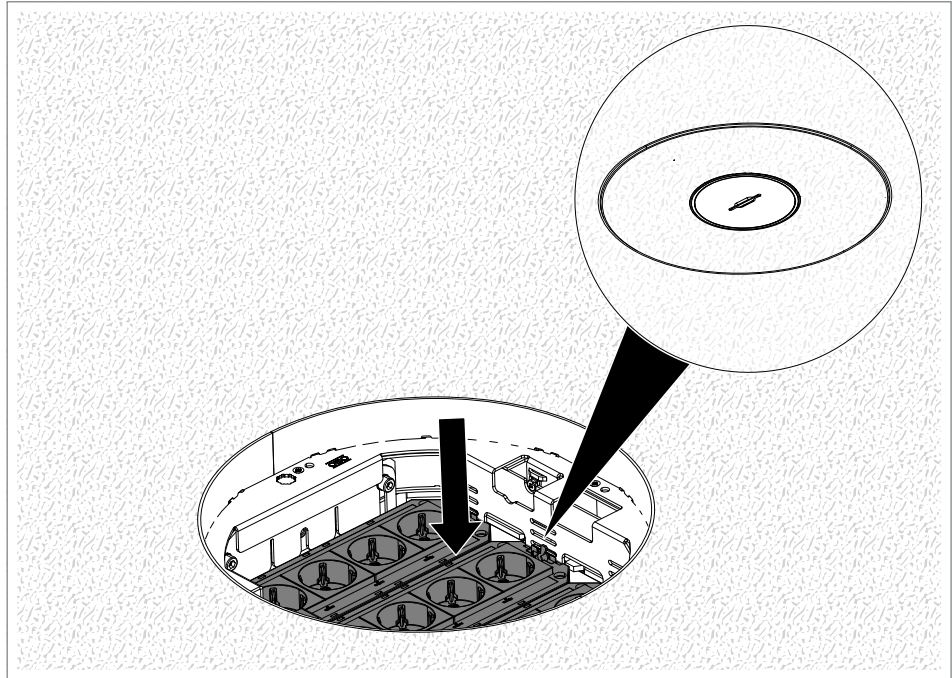
Destruction-free dismantling of the cassette is not possible.

8 Disposing of the cassette

Comply with the local waste disposal regulations.

- Screed protection cover: As scrap metal (aluminium and galvanised steel)
- Holding claws: As scrap metal (galvanised steel)
- Screws: As scrap metal (galvanised steel)
- Plastic parts: As plastic

– Packaging: As household waste (depending on packaging type)

9 Technical data

	Nominal size R9
Art.-No.	7409650, 7409651, 7409495, 7409497
Design	Round cassette
Care information	For wet-cleaned floors (housing with a blanking cover for inspection openings, housing with a tube as a cable outlet in the cover)
System	
Minimum system installation depth	From 140 mm (UGD55) From 165 mm (UZD)
Underfloor device socket	UZD 250 (e.g. 7410022) UGD55 250 (e.g. 7410060) UZD 350 (e.g. 7410023) UGD55 350 (e.g. 7410062)
Dimensions UZD 250 UGD55 250 UZD 350 UGD55 350	383 x 383 x 80 mm 367 x 367 x 55 mm 483 x 483 x 80 mm 467 x 467 x 55 mm
Product	
Material	1.4301 stainless steel, strip-galvanised steel
Height-adjustment range (combination of the screed and design screed layer)	73–113 mm
Cassette material	Stainless steel
Cassette dimensions L x W	Ø 304 mm
Floor care type (according to EN 50085-2-2)	Wet, dry
ISO apron height	12.5 mm

Tab. 3: Technical data

OBO Bettermann Holding GmbH & Co. KG
P.O. Box 1120
58694 Menden
GERMANY

Technical Office
Tel.: +49 (0)2373 89-1300

technical-office@obo.de

www.obo-bettermann.com

Date 12/2025

251054.02

Building Connections

